

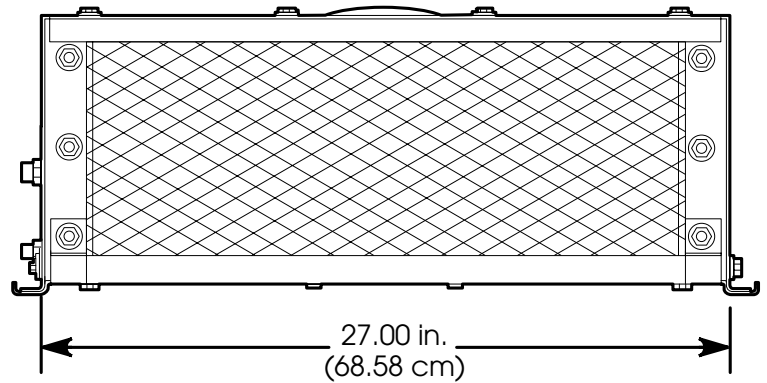

Red Dot Remote Mount Condenser R-9720 Series

TECHNICAL SALES BULLETIN AND SERVICE PARTS LIST DIMENSIONS

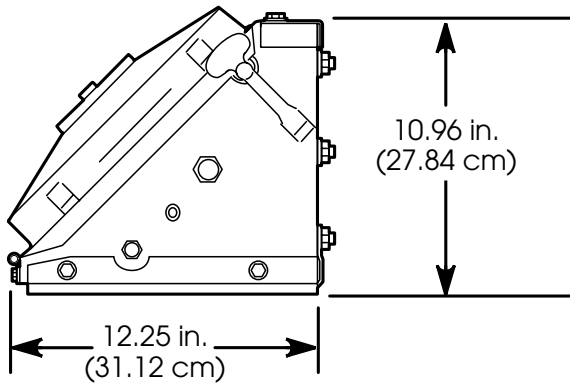

SPECIFICATIONS

- Capacity:** 27,000 BTU/Hr (6804 kcal/h) @ 150°F Condensing Temp. and 100°F Entering Air
- Air Flow:** 740 CFM (1257 m³/h)
- Current Draw:** 12.3 Amps @ 13.6 Volts D.C.
6.17 Amps @ 27.2 Volts D.C.
- Condenser Coil:** Copper Tubing, Aluminum Fins and Plated Steel Headers
- Motor:** Single Speed, Long Life Sealed With Pre-Lubricated Bearings
- Fan:** 10" Dia., Pancake Motor Fan Assembly
- Weight:** 38 Lbs. (17.24 Kg.)

ELECTRICAL SCHEMATIC

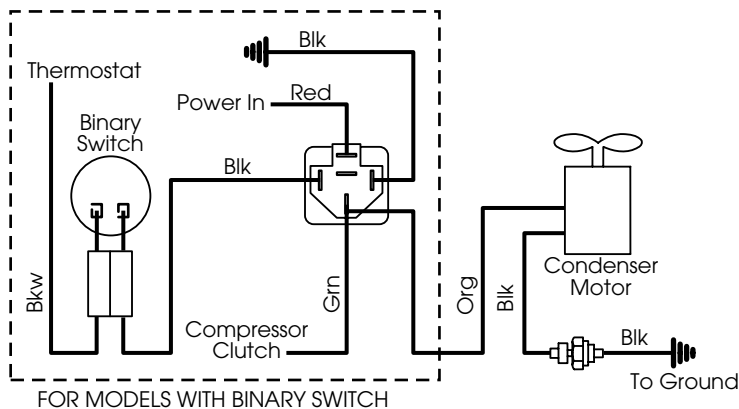

SCHEMATICS

PLUMBING SCHEMATIC

